

Chip-Down NVIDIA Quadro Pascal GP104, 4 SDI In/Out, Analog In/Out

KEY FEATURES

- NVIDIA GP104, 8.7 TFLOPS, GPGPU Engine
- Chip-down WOLF design and fabrication meets military and aerospace specifications
- Up to four 3G-SDI inputs and four 3G-SDI outputs
- Up to four analog inputs and/or outputs
- 16 GB GDDR5 memory with NVIDIA GPUDirect™ DMA technology
- Operating power configurable hard cap: 65 – 130W

ADDITIONAL FEATURES

- 4 DisplayPort 1.4 digital video outputs:
 - support for High Dynamic Range (HDR) video
 - 4K at 120Hz or 5K at 60Hz with 10-bit color depth
- Pascal GPGPU parallel processing:
 - 2560 CUDA® cores
 - CUDA Toolkit 9.0, CUDA Compute version 6.1
 - OpenCL™ 1.2, DirectX® 12, OpenGL 4.5, Vulkan
- Memory width: 256-bit width
- Maximum memory bandwidth: 243 GB/s
- NVENC/NVDEC accelerator for HEVC (H.265) and AVC (H.264) hardware encode/decode
- PCIe x16 Gen3
- Windows and Linux drivers

SPECIFICATIONS

- Manufactured in North America with full component traceability
- Component derating meets or exceeds NASA and Rome Labs specifications for reliability
- High level of ruggedization:
 - Rugged air-cooled or conduction-cooled
 - Operating temperature: -40° to +85°C
 - Vibration (sine wave): 10G peak, 5 - 2000Hz
 - Shock: 30G peak for air-cooled, 40G peak for conduction-cooled
- Front I/O and Rear I/O configurations
- Supported VPX configurations:
 - VPX-REDI (ANSI/VITA 48.x)
 - OpenVPX (ANSI/VITA 65)



OVERVIEW

The VPX3U-GP104-SDI-4IO module uses a WOLF chip-down design which includes both an advanced NVIDIA® Quadro® Pascal™ GPU and WOLF's Frame Grabber eXtreme (FGX). This module accepts up to four simultaneous 3G-SDI inputs and CVBS/STANAG inputs. The video data can be routed to the Pascal GPU for processing or encoding, and then output in several formats, including up to four 3G-SDI, CVBS/STANAG, and optionally to DisplayPort, HDMI or DVI.

These modules are designed and manufactured specifically for use in the harsh environments encountered in military and aerospace applications. They have been designed to pass MIL-STD-810 and DO-160 environmental tests. They have been manufactured to IPC-A-610 CLASS 3 and IPC 6012 CLASS 3 for high reliability electronic products. They are compliant with IPC J-STD-001 soldering standards.

The WOLF Frame Grabber eXtreme (FGX) is the engine that provides the board with conversion of video data from one standard to another, with a wide array of video input and output options for both cutting-edge digital I/O and legacy analog I/O. The FGX has direct memory access (DMA) to the Quadro Pascal's GPU memory for GPU processing and complex analysis. By including both the versatile FGX and a high performance Quadro Pascal GPU on one board WOLF's I/O and processing solution avoids the SBC data rebroadcast traffic jams that commonly occur with a 2-board solution.



WOLF-1110 Chip-Down VPX Module

VPX3U-P5200E-SDI-4IO

WOLF-1110

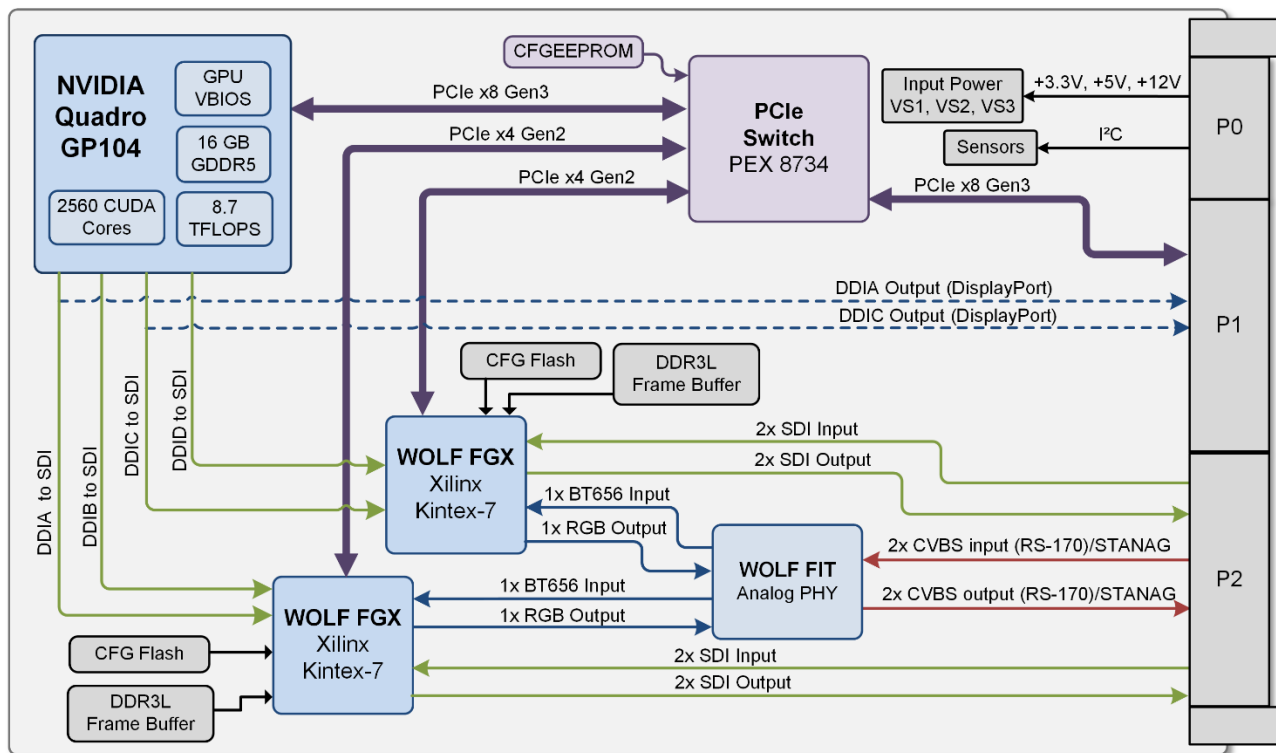

- Inputs and Outputs:**
- SDI Inputs: 4x 3G-SDI
 - SDI Outputs: 4x 3G-SDI
 - CVBS/STANAG 3350 Inputs & Outputs: options for 2 Inputs & 2 Outputs (as shown), 4x Output only, 4x Input only
 - Additional Digital Output options: DisplayPort, HDMI, Single Link DVI

MANUFACTURING AND QUALITY ASSURANCE

WOLF stress tests to MIL-STD-810 (United States Military Standard for Environmental Engineering Considerations and Laboratory Tests) and MIL-HDBK-217 (Reliability Prediction of Electronic Equipment); Alternately will stress test to RTCA DO-160 (Environmental Conditions and Test Procedures for Airborne Equipment) on request.

WOLF products meet the following quality standards:

- ISO 9001:2015 (Quality management systems)
- IPC-A-610 CLASS 3 (Acceptability of Electronic Assemblies)
- IPC 6012 CLASS 3 (Qualification and Performance Specification for Rigid Printed Boards, Class 3 for High Reliability Electronic Products)
- IPC J-STD-001 Certified (Requirements for Soldered Electrical and Electronic Assemblies)

Boards are manufactured to meet the following standards:

- SAE AS9100D (Quality Management System - Requirements for Aviation, Space and Defense Organizations)
- SAE AS5553 (Counterfeit Electronic Parts; Avoidance, Detection, Mitigation, and Disposition)



WOLF-1110 Chip-Down VPX Module